



## UT-2 Flexiwheel

The UT-2 Flexiwheel is suitable for internal or external circumferential welding of large cylindrical workpieces due to its compact design & a steering wheel. The tractor can be equipped with multi-kind of branded power source such as Lincoln DC-1000; Miller DC-1000...etc

The process welding controller exact presetting and control of welding parameters is done on the instrument panel, which is equipped with a digital display. The Flexiwheel is fully mobile and can be modified with optional kit for four wheels drive; two wheel with guiding buggy.

The compact, efficient design makes it easy to move the tractor unit from one place to another, such as between different welding workpieces. The tractor is equipped with a handle to disengage the gear, so the Flexiwheel can easily be pushed to another place.

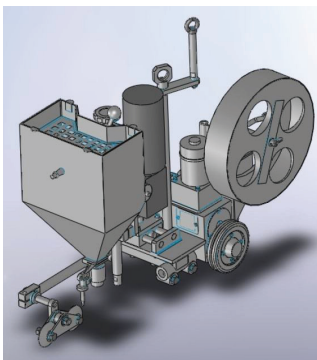

Max load	: 1000 A
Min. Work pieces diameter	: 800mm
Duty cycle	: 100%
Travel speed	: 0.2 ~ 1.6m/min
Weight, excl wire & flux	: 40kg
Dimensions	: 700x400x550 mm



## UT-6 Heavyarc

The UT-6 Heavyarc SAW welding tractor is a heavily-dimensioned self-propel 4 wheel drive. The tractor can be equipped with multi-kind of branded power source such as Lincoln DC-1000; Miller DC-1000...etc

The advanced electronic control panel provides high precision and which is equipped with a digital display. The UT-6 Heavyarc is easy to use and once it is running, it requires only the supervision of the operator. The compact, efficient design makes it easy to move the tractor unit from one place to another, such as between different welding workpieces.

Max Welding current	: 1250 A
Duty cycle	: 100%
Electrode diameter, (mm)	: 1.6 ~ 5.0
Wire feed speed, (m/min)	: 0.4 ~ 3.5